

IC200 PRO INDOOR CYCLING™

INSTRUCTION MANUAL

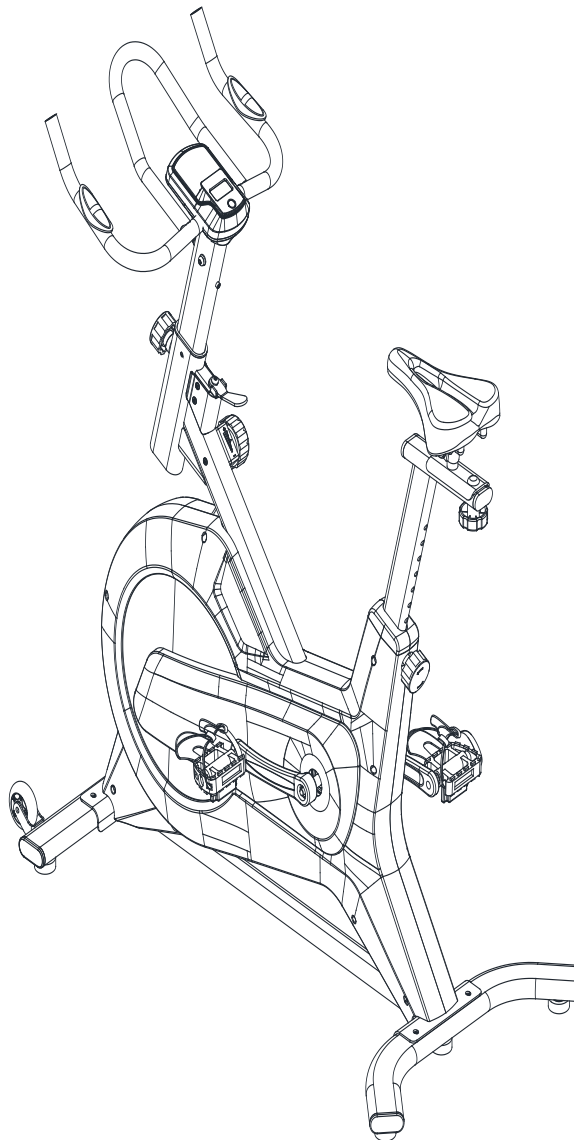

Scan the QR code for a step-by-step video guide on how to assemble your exercise bike.

Scan the QR code to view our support center for more technical resolutions and FAQ's about your item.



CONTENTS

Exploded diagram.....	4
Parts list.....	5

1. SAFETY INSTRUCTIONS

User safety precautions.....	6
Prior to use.....	6
During use.....	6
Exercise safety precautions.....	6
Facility safety precautions.....	7
Warning stickers.....	7

2. ASSEMBLY

Preparing the site.....	8
Diagram.....	8
Content listing.....	9
Box contents.....	9
Tools pack.....	9
IC200 PRO assembly.....	10
Monitor configuration.....	12
Testing the bike operation.....	13
Specifications.....	13

3. OPERATION

Emergency stop function.....	14
Data readouts.....	14
Tension adjustment.....	14
Pedal strap adjustment.....	15
Seat adjustment.....	15
Handlebar adjustment.....	15
Transporting the bike.....	16

4. MAINTENANCE

Preventive maintenance activities.....	17
Exercise bike cleaning.....	18
Bike balance.....	19

5. ADDITIONAL INFORMATION

Contact information.....	20
Disclaimer.....	20

PARTS LIST

No.	Description	Qty.
1	Front Stabilizer	1
2	Hexagon Nut M8*H5.5*S14	5
3	Foot Pad $\phi 43*14*M8*25$	5
4	End Cap PT70*30*20	4
5	Screw M6*12*S5	2
6	Bearing 608ZZ	4
7	Transport Wheel $\Phi 71*\Phi 19*24$	2
8	Screw $\Phi 7.8*30*M6*15*S5$	2
9	Screw M8*20*S6	4
10	Spring Washer d8	7
11	Washer d8* $\Phi 16*1.5$	7
12	Rear Stabilizer	1
13	Knob M16*1.5*27* $\Phi 56$	2
14	Bushing PT80*40*PT70*30*L130	1
15	Brake Block 68*75*39.2	1
16	Screw M5*7* $\Phi 10$	6
17	Brake Cable $\Phi 1.5*255*42$	1
18	Bolt M6*10*H26*S5	1
19	Brake Handle	1
20	Washer $\Phi 8.5*\Phi 23.5*3$	1
21	Spring $\Phi 1.2*\Phi 11*21*N7$	1
22	Cable Base t3*25*23	1
23	Nylon Nut M6*H6*S10	8
24	Hexagon Bolt M6*10*S10	1
25	Washer d6* $\Phi 16*1.5$	1
26	Bearing 6001-2RS	4
27	Idle Pulley $\Phi 39*\Phi 34*24$	1
28	Wave Washer d12* $\Phi 15.5*0.3$	1
29	Seat	1
30	Seat Slider	1
31	Seat Post	1
32	End Cap PT50*25*16	2
33	Washer d10* $\Phi 30*2.5$	1
34	Knob M10* $\Phi 58*32$	1
35	Cover 99.3*83.5*24.7	1
36	Bushing PT70*30*PT60*20*L145*10	1
37	Crank Plug $\Phi 25*7$	2
38	Hexagon Nut M10*1.25*H7.5*S14	2
77	Nut M12*1*H5*S19	3
78	Handlebar	1
81	Main Frame	1
82	Washer d5* $\Phi 13*1$	1
83	Screw M5*16* $\Phi 8$	1
84	Pulse Sensor	2
85	Screw ST4.0*19* $\Phi 11$	2
86	Plug $\Phi 12*11*\Phi 3$	2
87	Meter	1
88	Trunk Line	1

No.	Description	Qty.
39L/R	Crank	2
40L/R	Pedal	2
41	Screw ST4.2*16* $\Phi 8$	6
42	Screw ST4.2*19* $\Phi 8$	10
43L/R	Belt Cover	2
44	C Clip d17	1
45	Bearing 6203-2RS	2
46	Bushing $\Phi 22*\Phi 18*5.5$	1
47	Magnet $\Phi 15*7$	1
48	Belt Wheel $\Phi 220*20*\Phi 17.1*4-\Phi 6*\Phi 60-6PJ$	1
49	Middle Axle $\Phi 17*188*59.5*78*4-\Phi 6.1*\Phi 60$	1
50	Bolt M6*16*S10	6
51	Belt	1
52	Tension Knob	1
53	Spring Washer d6	2
54	Washer d6* $\phi 12*1.2$	2
55	Ring-Shield d12	2
56	Magnet 40*25*10	7
57	Magnet Holder 45.5*130*10.5	2
58	Magnetic Plate	1
59	Magnetic Plate Shaft $\phi 12*53.5*47.4*M6$	1
60	Screw ST3*10* $\Phi 5.6$	8
61	Spring $\Phi 1.5*\Phi 15*54*N9$	2
62	Brake Pad 60*27*5	1
63	Brake Pad Holder	1
64	Screw M6*16*S5	2
65	Brake Connected Plate	1
66	Hexagon Nut M12*1*H11*S18	2
67	Hexagon Nut M10*1.0	1
68	Bolt M6*50* $\Phi 12*4$	1
69	U-shaped bracket	1
70	Hexagon Nut M12*1*H7*S19	1
71	Idler shaft	1
72	Flywheel	1
73	Flywheel Axle	1
74	Handlebar Post	1
75	Screw M5*8* $\Phi 10$	1
76	Screw M8*16*S6	3
89	Sensor Wire	1
90	PU Washer	1
91	Tension Knob Bracket	1
92	Wave Washer d17* $\Phi 22*0.3$	1
93	Washer d5* $\phi 10*1.0$	4
94	Crank Cover	2
95	Protective sleeve	1
A	Allen Wrench S6	1
B	Spanner S13*15	1

1 SAFETY INSTRUCTIONS

Please pay attention to the following instructions before operating this bike.

USER SAFETY PRECAUTIONS

PRIOR TO USE

- Assemble the bike according to the instruction manual.
- Consult your doctor before beginning any exercise program.
- Read instructions.
- Read warning labels.
- Read emergency stop procedures.
- Maximum user weight is 100kg/ 15.7 St.
- Inspect unit. If damaged, DO NOT USE.
- Ensure every bolt and screw is securely tightened.

DURING USE

- DO NOT use for stretching and DO NOT attach straps or other devices.
- DO NOT allow children aged 12 or younger to be on or near the machine.
- Stop exercising if you feel faint, dizzy, or encounter pain.
- Keep all clothing and accessories clear of moving parts.
- DO NOT jump onto the exercise bike.

WARNING

- Keep water and liquids away from electrical parts.

EXERCISE SAFETY PRECAUTIONS

- Use sports clothes and gym shoes.
- DO NOT use with bare feet.
- This model should only be used at home, DO NOT use for commercial purposes.

FACILITY SAFETY PRECAUTIONS

- DO NOT operate this bike in damp or wet locations.
- Use caution when getting on or off the bike.
- Check the exercise bike for worn or loose components before each use. DO NOT use until worn or damaged parts are replaced.
- Maintain regularly. Refer to *Preventive Maintenance* chapter.
- DO NOT use the bike if: (1) the bike is not working adequately or (3) the bike has been dropped or damaged.
- DO NOT use the exercise bike outdoors.
- Read the instruction manual completely before using the bike.
- Ensure all users wear appropriate footwear on JLL® equipment.
- Set up and operate the bike on a level surface. DO NOT operate in small restricted areas or on plush carpet.
- As far as possible provide the following clearances: 0.5 m at each side and 2 m at the back. Be sure your exercise bike is clear of walls, equipment and other hard surfaces.
- DO NOT modify the bike in any way. Any modifications will void the warranty.
- All the data displayed by the monitor is for reference purposes only.

WARNING STICKERS

Warning stickers indicate a potentially hazardous situation which, if not avoided, could result in death or serious injury. Carefully read the following caution and warning labels before using the unit.

⚠ WARNING

It is strictly forbidden to touch any moving parts of the bike.

⚠ WARNING

Keep small children and pets a safe distance from bike when in use.

2 ASSEMBLY

PREPARING SITE

To find the ideal location to set up this bike, ensure that:

- Area is well illuminated and well ventilated.
- Surface is level.
- There is enough space to access the unit and emergency dismount. If it is possible, keep the following clearances: 0.5 m at each side and 2 m at the back.
- The bike is placed in an environment with a relative humidity range of 30-50%. Please ensure the temperature is kept constant. Do not use in a moist or damp environment as this may impact on the integrity and performance of the machine.

DIAGRAM

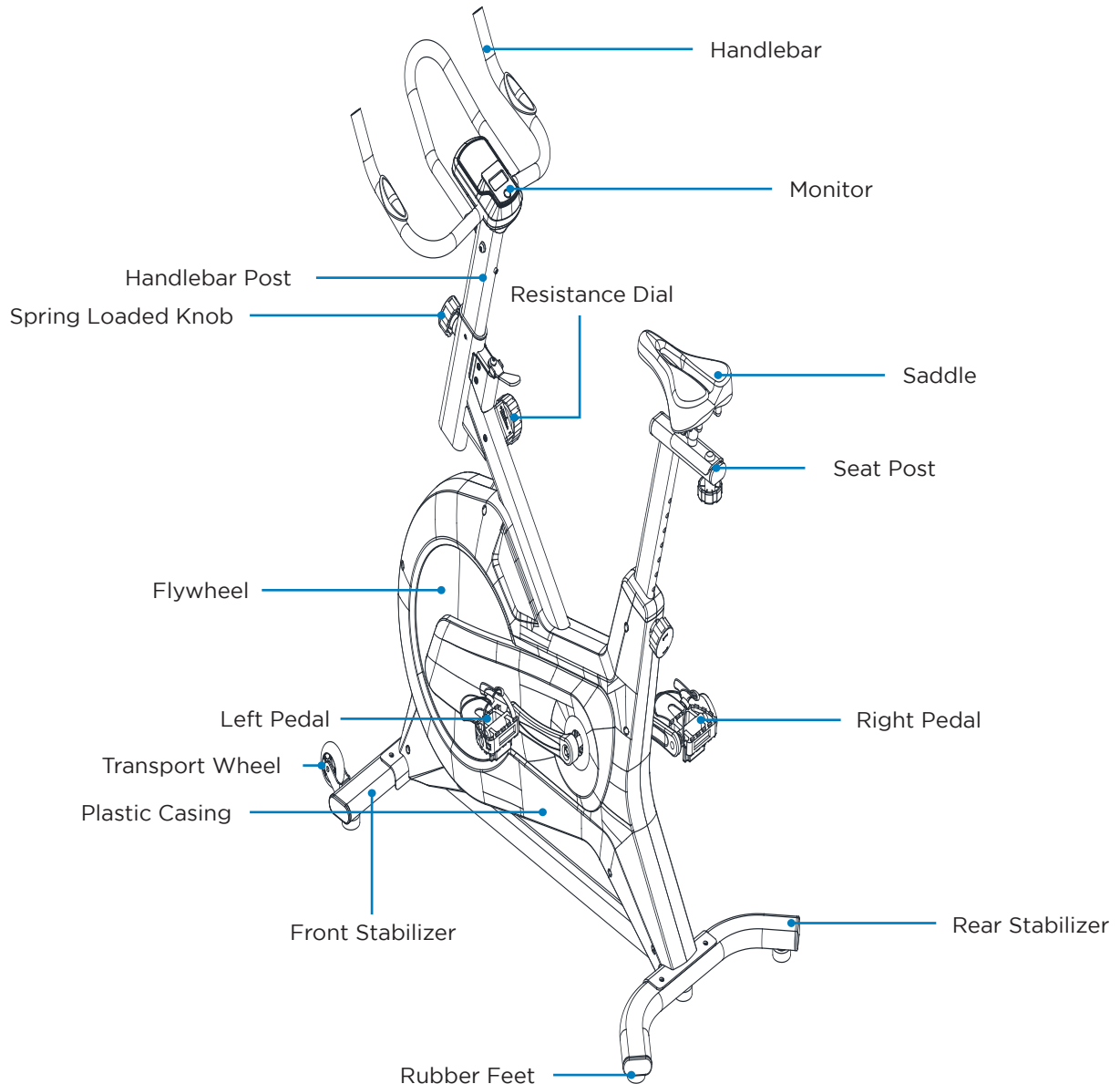

CONTENT LISTING

See diagram (left) and content listing (below) for the exercise bike box contents. See *Customer Service* chapter for contact information if any parts are missing.

BOX CONTENTS

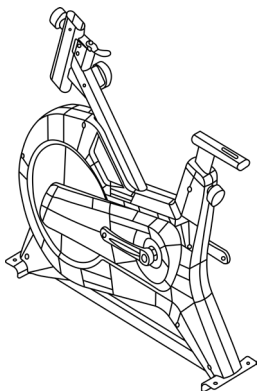

Exercise Bike Base

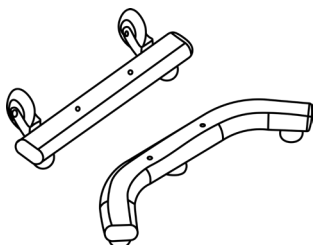

Front and Rear Stabilizers

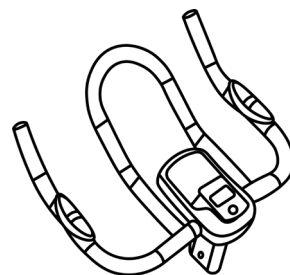

Handlebars

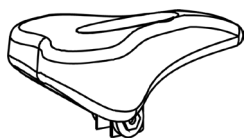

Saddle

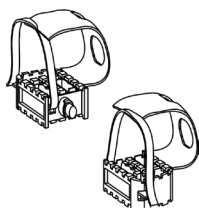

Pedals x2

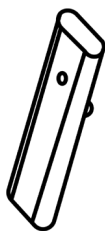

Handlebar Post

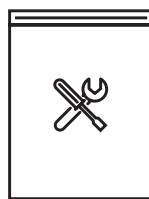

Tools Pack²

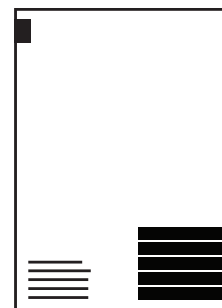

Manual

² TOOLS PACK



M8*20*S6 Bolt
x4



M8*16*S6 Bolt
x3



d8 Flat Washer
x7



d8*16*1.5 Spring Washer
x7



d10*30*2.5 Flat Washer
x1



S6 Allen Key
x1



S13*15 Spanner
x1



M10*58*32 Knob
x1

IC200 PRO ASSEMBLY

The bike has been assembled and tested at the factory, so you shouldn't have any problems putting all the parts together. Components are designed to fit together, and only basic tools are required for the assembly process. Inside the box you will find a Tools Pack (Hex Allen Key, Multi-tool, Washers and Bolts). See previous page.

To assemble your JLL IC200 PRO please follow these easy steps:

STEP 1

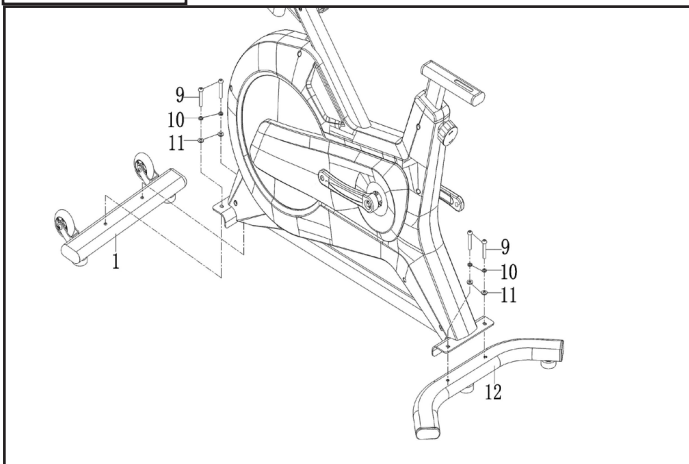

Attach the front and rear stabilizers to the main frame using 4 x M8*20 Screws (Part 9), 4 x spring washers and 4 x flat washers.

STEP 2

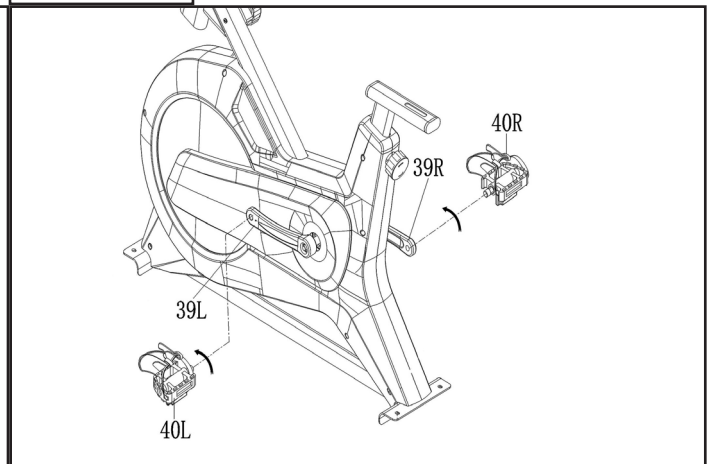

Attach the right and left pedals to their corresponding cranks, turn the right pedal clockwise and the left anti-clockwise.

STEP 3

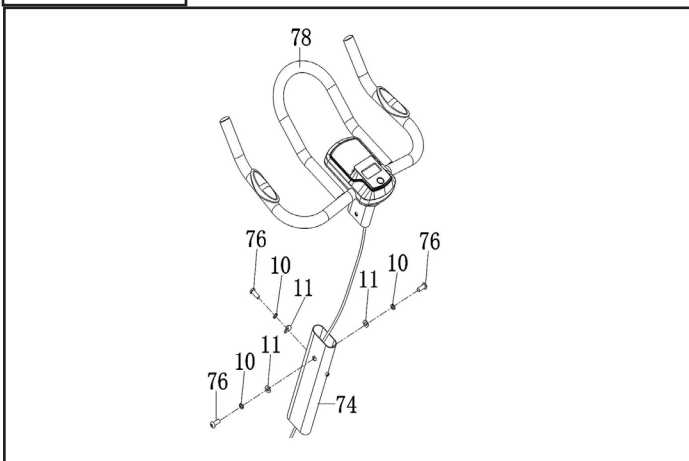

Attach the handlebars to the handlebar post by feeding the wire through the post and securing using 3 x M8*16 Screws, 3 x spring washers and 3 x flat washers.

STEP 4

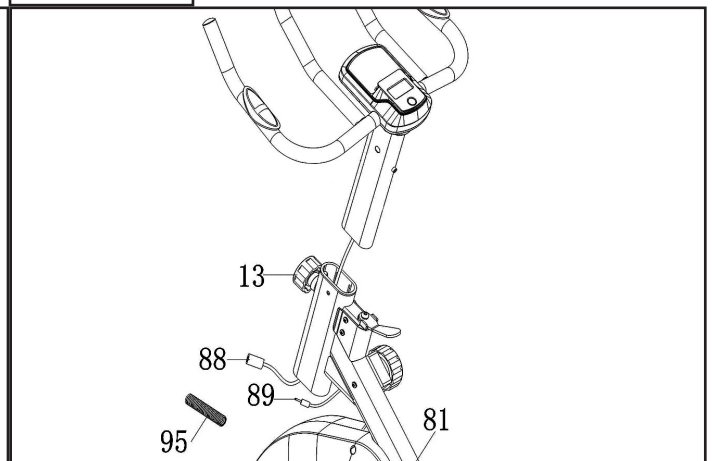

Loosen the adjustment knob on the front of the bike and insert the handlebar post into the frame also feeding the wire through. Then tighten the knob back up.

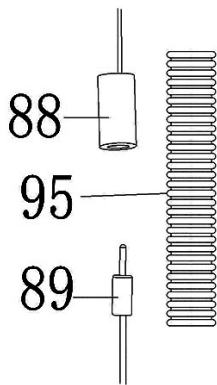
STEP 5

Make sure the sensor wire feeds through the protective sleeve and connect to the other end of the wire from the frame.

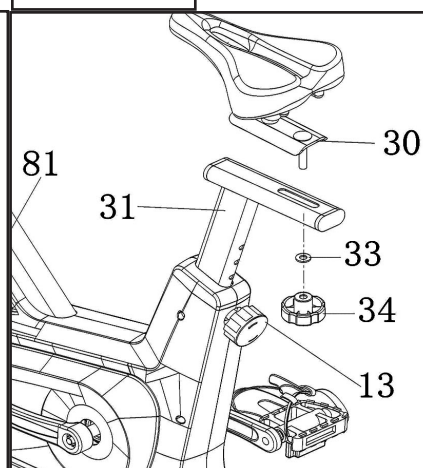
STEP 6

Attach the saddle to the seat post and secure using a large washer and the M10 knob.

⚠ WARNING: HEAVY EQUIPMENT

- It is recommended that at least two people lift, move and assemble the bike.
- Use safe lifting methods.

MONITOR CONFIGURATION

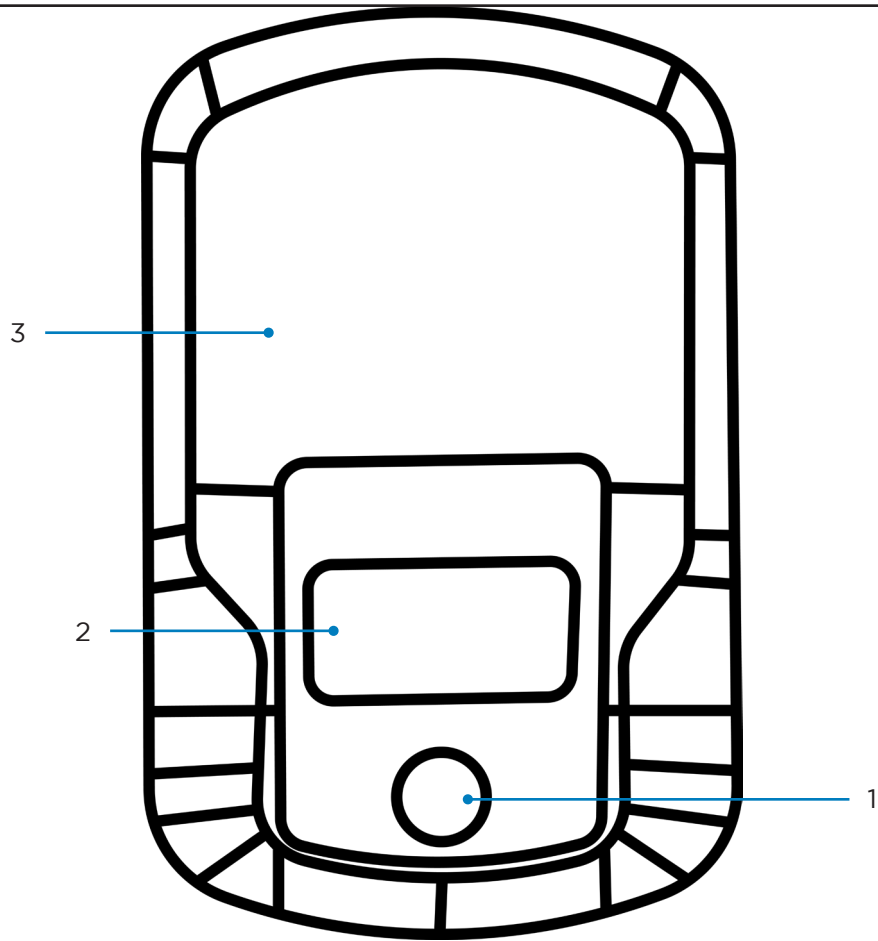

1	Button	3	Stand
2	Display Screen		

TESTING THE BIKE OPERATION

Use the following instructions to test the resistance and correct operation of the bike.

1. Without anyone on the bike, turn the resistance dial both clockwise and anti-clockwise and check to see if the brake pad moves closer or further away from the flywheel.
2. Now sit on the bike and begin to pedal, again turn the resistance dial in both directions and check to feel the difficulty of pedalling changing.
3. Whilst pedalling press down the resistance dial to check the emergency stop function.
4. Whilst pedalling on the bike make sure there are no noise issues or wobbling coming from the bike.

SPECIFICATIONS

Display	LCD Displays: Time, speed, distance, calories, pulse and scan mode.
Transport	Built-in wheels.
Flywheel	7kg Flywheel
Resistance	8 levels of magnetic resistance
Safety	Emergency stop friction pad
Working Temperature	5° C - 40° C
Crank	3 piece crank system on the pedals making it stronger and more reliable.
Seat	8 levels of adjustable seat height.
Pedals	Fitted pedals with foot cage
Handlebars	5 levels of adjustable height
Maximum User Weight	100kg, 15.7 St or 220 lb
Occupying Area	119.5 cm (Length) x 55.5 cm (Width) x 110.5 cm (Height)
Packaging Dimensions	107 cm (Length) x 25 cm (Width) x 87.5 cm (Height)
Gross Weight	35.5kg
Net Weight	31kg

3 OPERATION

Read all instructions, warnings and safety procedures located in the *Safety* chapter before using the bike.

EMERGENCY STOP FUNCTION

The resistance dial also functions as the emergency stop. In an emergency situation, press down firmly on the dial, this will cause the flywheel to come to a stop.

DATA READOUTS

As you exercise, the bike keeps track of the following data:

- **Time:** The total time you have been working out. Display time as *hours: minutes*.
- **Speed:** Your current speed, displayed in kilometres per hour (km/h).
- **Distance:** The total accumulated distance, in kilometres during your workout.
- **Calories:** The total accumulated calories burned during your workout.
- **Pulse:** Your current pulse rate during your workout.
- **Scan Mode:** Displays each function continuously one after another.

TENSION ADJUSTMENT

To increase the tension, rotate the knob clockwise. To decrease the tension, rotate the knob anti-clockwise. 1 will indicate the lowest and 8 being the hardest tension.

The red brake handle is the emergency brake. Use this safety feature in any situation where you need to get off the bike quickly or stop the bike's flywheel.

Simply press down on the handle firmly.

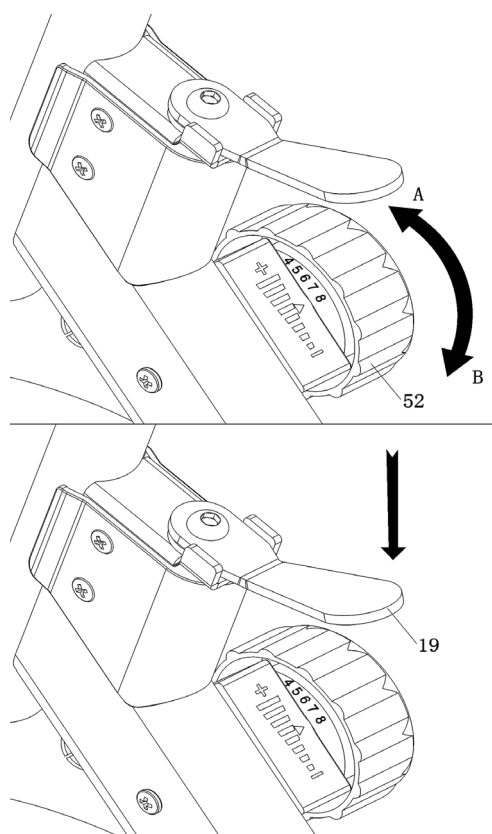

PEDAL STRAP ADJUSTMENT

If the strap is loose, press down the buckle and pull the strap down to secure it tighter.

(Figure B)

If the strap is too tight, press down the buckle and pull the strap up to loosen it.

(Figure A)

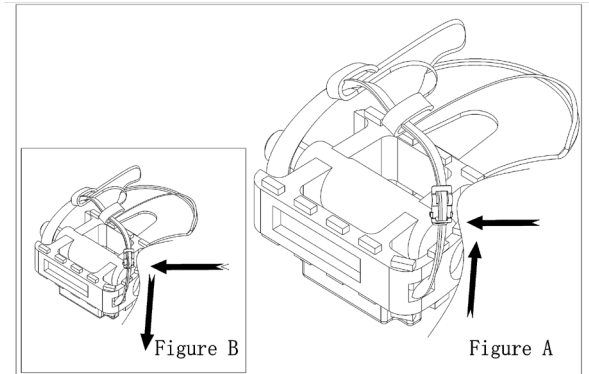

SEAT ADJUSTMENT

To adjust the seat height loosen the knob on the back of the bike and pull it out. This knob will be spring loaded. Raise or lower your seat and then reinsert the knob and secure in place.

To adjust the seat forward or back loosen the knob underneath the saddle, slide it to your desired position and tighten back up.

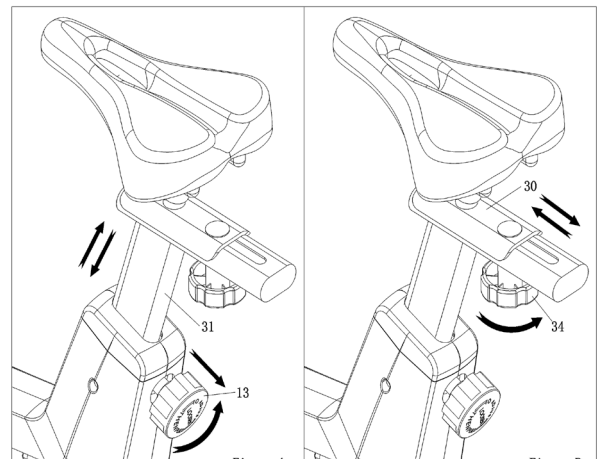

HANDLEBAR ADJUSTMENT

To adjust the handlebars loosen the knob on the front of the bike and pull it out. This knob will also be spring loaded. Then slide the handlebar post up or down and secure the knob back in place.

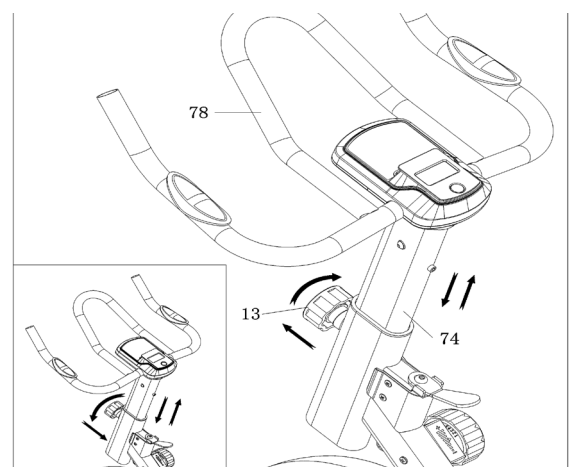

TRANSPORTING THE BIKE

To move the bike first make sure the handlebars are secure, then stand in front of the bike and firmly grab hold of the handlebars and tilt the bike towards you. Make sure the transport wheels are touching the ground and then you can roll the bike to your desired location.

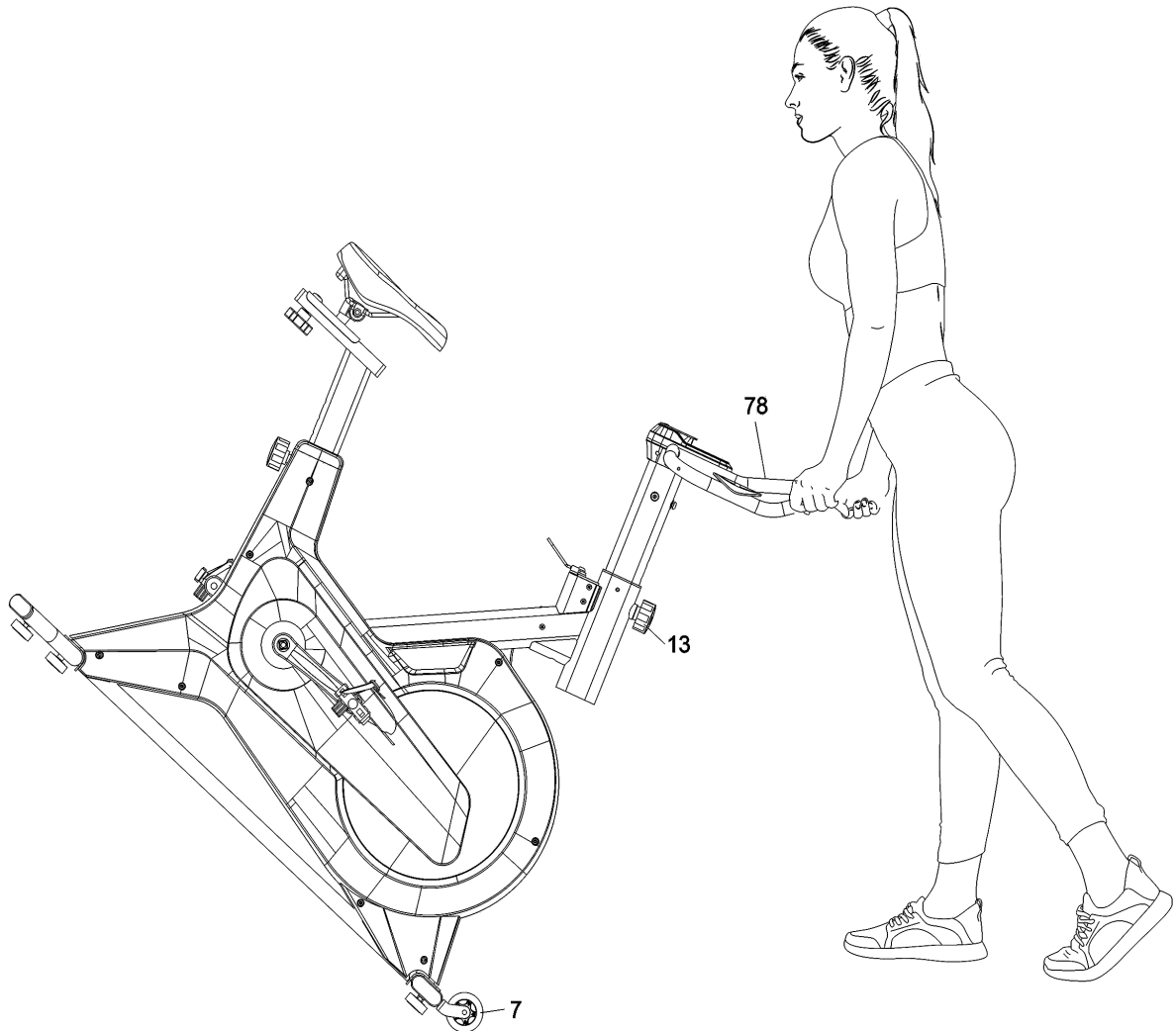

4 MAINTENANCE

Maintenance must be performed on a regular basis. Performing maintenance actions can aid in providing safe and trouble-free operation of all JLL® equipment.

JLL® are not responsible for performing regular inspection and maintenance actions for your machine. JLL® representatives are available to answer any questions that you may have on +44 (0)800 6123 988.

PREVENTIVE MAINTENANCE ACTIVITIES

Every JLL® bike that comes from the factory is already maintained, however, you just need to follow simple steps to maintain it. Keeping the bike in a clean state will help to prolong its life. Perform regular preventive maintenance to ensure normal operation of the unit. Keep a log of all maintenance actions to assist in staying current with all preventive maintenance activities. JLL® is not responsible for performing regular inspection or maintenance.

Read all instructions and warnings listed both in this chapter and in the *Safety* chapter. Contact JLL® Customer Service on +44 (0)800 6123 988 for any maintenance or service concerns.

Requirements:

- Water
- Dry cloth
- Vacuum

WARNING

1. Only use water to clean and dust. Do not use any cleaning product because they may damage the bike.
2. Be careful not to spill or get excessive moisture between the edge of the monitor, as this might create an electrical hazard or cause failure of the electronics.
3. Direct spraying could cause damage to the electronics and may void the warranty.

Depending on where the bike is placed, you may experience dry air, causing a common experience of static electricity. You can notice that by walking across a carpet and then touching a metal object. On your bike you may experience a shock due to the build-up of static electricity on your body and the discharge path of the bike. If you experience this type of situation, you may want to increase the humidity to a comfortable level through the use of a humidifier.

Check your machine regularly for rust. If rust starts to appear on the screws it means the item is not housed in the correct environment and will need to be moved to a more suitable room. Any rust will indicate there may be moisture in the air and as a result this could impact on the integrity and performance of your machine.

⚠ WARNING

1. Use only JLL® replacement parts.
2. Keep water and liquids away from electrical parts.
3. If you allow your machine to become rusty, this will affect your warranty.

EXERCISE BIKE CLEANING

Keep the pedals free of dust and debris for smooth running and preventing injuries. Dust/debris may cause damage to the chain and other moving parts.

After every workout use a neat, dry cloth for cleaning the bike and the handlebars to prevent the item of corrosion. Wipe away any sweat that may have dripped onto the bike. Avoid scratching the display by using a soft cloth.

Vacuum or sweep the floor underneath and around the bike. A treadmill mat can help to reduce dust.

For further cleaning, use a soft cloth or paper towel dampened with water. Do not use abrasive or chemical cleaning agents.

EXERCISE BIKE BALANCE

Place the bike on a level floor to avoid it being off-balance. If that is not possible, level the bike by adjusting the rubber feet located underneath the stabilizers.

Check if the bike is balanced:

1. Stand in front of the unit with your hands on the handlebars.
2. Gently rock the bike from side to side checking for any movement.

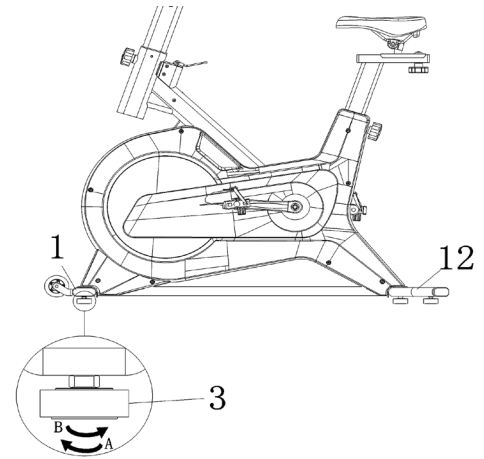

⚠ WARNING: EQUIPMENT HAZARD

To avoid serious injury or death:

- Replace worn or damaged components immediately and do not use until repair is completed.

5 ADDITIONAL INFORMATION

CONTACT INFORMATION

In case any issues arise, please do not hesitate to contact our Customer Service team on +44 (0)800 6123 988 or email us at **CONTACT@JLLFITNESS.CO.UK**

You can also visit our support centre at **SUPPORT.JLLFITNESS.CO.UK** for maintenance and assembly articles & videos.

DISCLAIMER

- You should consult your physician, doctor or other health care professional before starting or taking part in any of our workout guides. It is your responsibility to evaluate your own health before taking part or performing any physical activity you may see associated with JLL Fitness Ltd.
- Always seek professional advice before changing your diet or starting any exercise program.
- JLL Fitness Ltd is not liable for any injuries or damages that may occur when assembling or using this exercise bike.
- By reading this you assume full responsibility for any injuries or changes to your physical well-being. You waive all rights and release JLL Fitness Ltd of blame from any injuries or damages to property that may occur whilst following our advice.
- This manual offers specific instructions on how to assemble and maintain your bike. Failure to follow these directions may result in your warranty being void.

WWW.JLLFITNESS.CO.UK

Follow us on Facebook and Twitter [@JLLFitness](#)

© JLL Fitness Ltd . All Rights Reserved.